

DISCLAIMER: This standard is approved by the Texas Engineering Practices Act. Its approval of this kind is made by T-007 for any purpose whatsoever. T-007 assumes no responsibility for the conversion of this standard to other formats or for incorrect results or damages resulting from its use.

DATE: FILE:

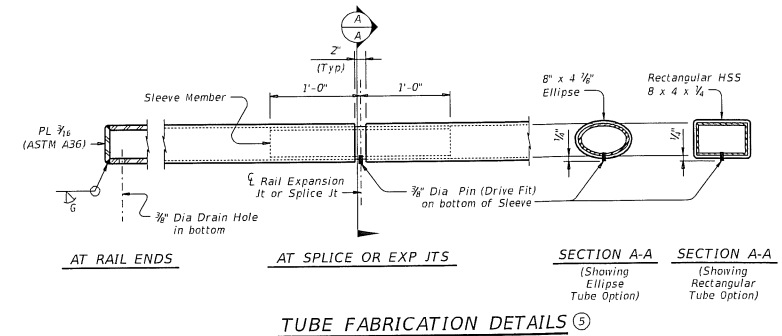
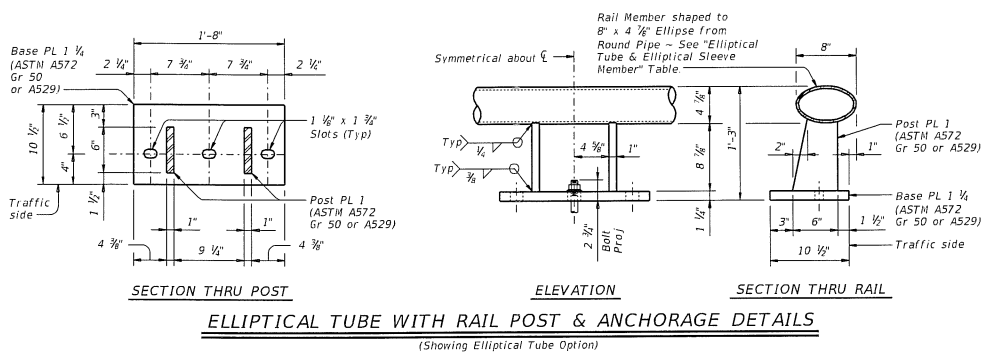

ELLIPTICAL TUBE & ELLIPTICAL SLEEVE MEMBER		
8" x 4 7/8" Ellipse	Elliptical Sleeve Member	
Material	Material	Thickness
6" Dia Std Pipe	ASTM A53 Gr B	0.353"
ASTM A53 E or S Gr B	ASTM A36 or A500 Gr B	0.339"
	API-5LX52	0.224"
6 3/4" O.D. Pipe x 0.138"	ASTM A53 Gr B	0.339"
	ASTM A36 or A500 Gr B	0.325"
	API-5LX52	0.188"

Notes: Other sections of equal or greater strength are acceptable for elliptical sleeves. The major and minor diameters of the rail member may vary +/- 0.1875" from plan dimension. However, the difference between the outside diameters of the elliptical sleeve and the inside diameters of the rail member must not exceed 0.25 inches.

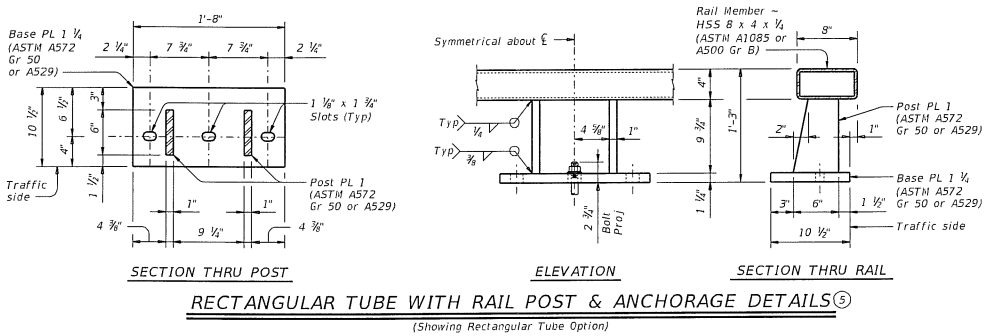

- ⑤ Unless directed otherwise by the Engineer, the Fabricator may use the rectangular tube in lieu of the elliptical tube for the rail member.
- ⑥ Increase 2" for structures with overlay.
- ⑦ 5 1/2" when vertical reinforcing has closer clear cover over horizontal reinforcing in abutment wingwalls or retaining walls on traffic side of wall.
- ⑧ See "Material Notes" for anchor bolt information.
- ⑩ Top longitudinal slab bar may be adjusted laterally 3" plus or minus to tie reinforcing.

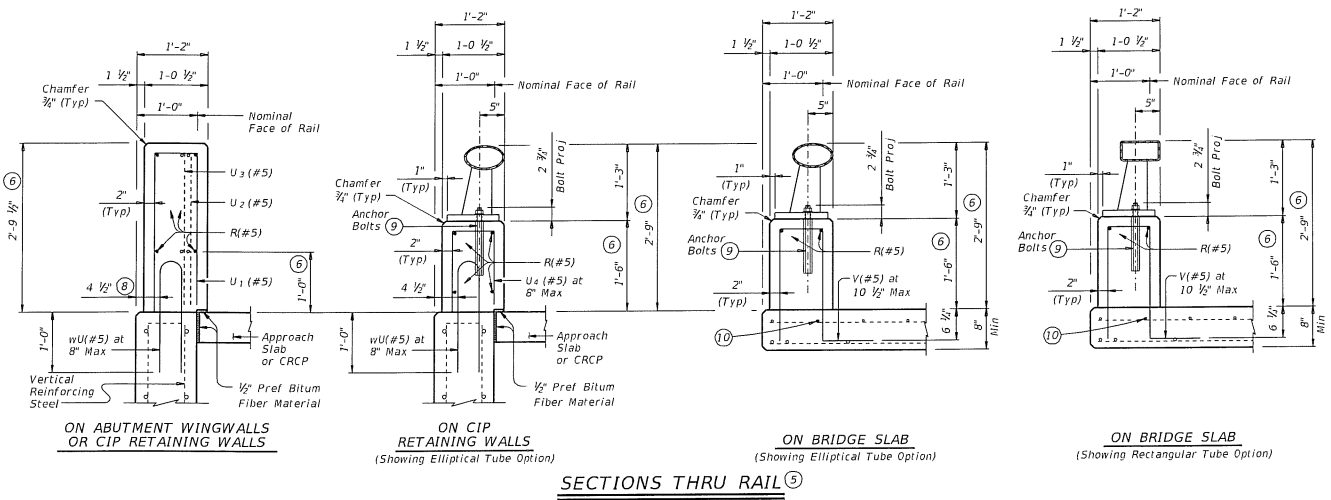

TRAFFIC RAIL			
TYPE T401			
FILE: T121006-18.039	DR: T1207	CR: T1207	DR: JTR
TXDOT: March 2018	COAT: SECT:	HR:	NSR: 66
PROJECT:	DATE:	CONTRACT:	SHEET NO.:

DISCLAIMER: This standard is approved by the Texas Engineering Practices Act. No warranty of any kind is made by TxDOT for any purpose whatsoever. TxDOT assumes no responsibility for the conversion or this standard to other formats or for incorrect results or damages resulting from its use.

RAIL DATA FOR HORIZONTAL CURVES			
RAIL MEMBERS	RADIUS TO FACE OF RAIL	MAX CHORD LENGTH	CONSTRUCT OR FABRICATE
	Over 2800'	29'-0"	Straight rail sections
	Over 1400' thru 2800'	14'-6"	To required radius (13)
	Over 700' thru 1400'	7'-3"	To required radius (13)
	Thru 700'	Zero	To required radius (13)

- (6) Increase 2" for structures with overlay.
- (9) See "Material Notes" for anchor bolt information.
- (11) Slots are not allowed in areas where there is a joint in the concrete parapet between rail posts.
- (12) Length shown for 6 1/2" Min bar embedment with no overlay. Adjust as required.
- (13) Shop drawings for approval required for tubular steel sections.

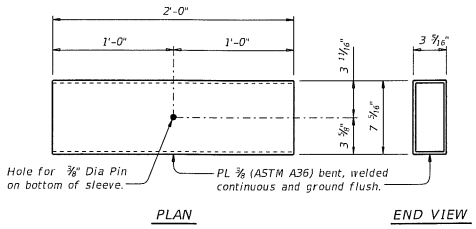

RECTANGULAR TUBE SLEEVE MEMBER DETAIL
(See Tube Fabrication Detail)

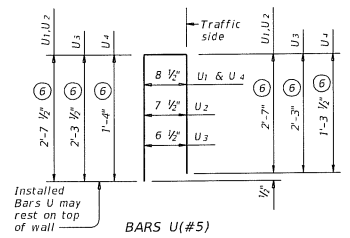

BARS U(#5)

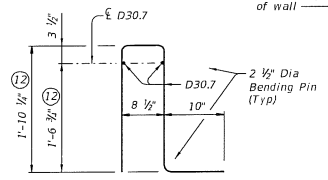

OPTIONAL WELDED WIRE REINFORCING (WWR)

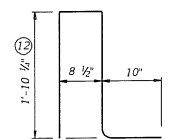

BARS V(#5)

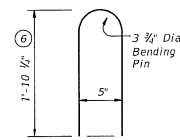

BARS wU(#5)

CONSTRUCTION NOTES:
 This rail may be slip-formed if approved by the Engineer when epoxy adhesive anchor bolts are used.
 Cap all open ends of tubular steel sections.
 At the Contractor's option anchor bolts may be cast with the parapet (See Cast-in-Place Anchor Bolt Options).
 Slip-forming parapet is not allowed if anchor bolts are cast with parapet wall.
 Test adhesive anchors in accordance with Item 450.3.3, "Tests". Test 3 anchors per 100 anchors installed. Perform corrective measures to provide adequate capacity if any of the tests do not meet the required test load. Repair damage from testing as directed.
 Rail parapet must be plumb unless otherwise approved. Steel posts must be square to the top of parapet. Use Type VIII epoxy mortar under post base plates if gaps larger than 1/8" exist.
 Rail member sections must have at least two posts but not more than four.
 Round or chamfer all exposed edges of steel components 1/8" by grinding prior to galvanizing.
 Chamfer all exposed concrete corners.

MATERIAL NOTES:
 Galvanize all metal components of steel rail system. Apply additional coatings when shown elsewhere on the plans. When plans require paint over galvanizing, follow the requirements for painting galvanized steel in Item 445, "Galvanizing" and when field painting, Item 446, "Field Cleaning and Painting Steel". Sleeve members and anchor bolts must receive galvanization prior to installation and only field paint after installation unless directed otherwise by Engineer.
 Anchor bolts must be 1/2" Dia ASTM A193 Gr B7 fully threaded rods with heavy hex nuts, one hardened steel washer (ASTM F436), and one (2 1/2" O.D.) steel washer each. Nuts must conform to ASTM A563 requirements. Embed fully threaded rods into parapet wall with a Type III, Class C, D, E, or F anchor adhesive. Minimum adhesive anchor embedment depth is 8". Anchor adhesive chosen must be able to achieve a nominal bond strength in tension of a single anchor, Na, of 17 kips (edge distance must be accounted for). Submit signed and sealed calculations or the manufacturer's published literature showing the proposed anchor adhesive's ability to develop this load to the Engineer for approval prior to use. Anchor installation, including hole size, drilling, and clean out, must be in accordance with Item 450, "Railing."
 Optional cast-in-place anchor bolts must be 1/2" Dia ASTM F3125 Gr A325 or A449 bolts (or A193 Gr B7 or F1554 Gr 105 threaded rods with one tack welded heavy hex nut each) with one heavy hex nut and one hardened steel washer (ASTM F436) plus one (2 1/2" O.D.) steel washer at each bolt. Nuts must conform to ASTM A563 requirements.
 Provide Class "C" concrete. Provide Class "C" (HPC) if required elsewhere.
 Provide Grade 60 reinforcing steel.
 Epoxy coat or galvanize all reinforcing steel if slab bars are epoxy coated or galvanized.
 Deformed Welded Wire Reinforcement (WWR) ASTM A1064 may be substituted for Bars R, and V, as shown. Provide the same laps as required for reinforcing bars.
 Provide bar laps, where required, as follows: Uncoated or galvanized - #5 = 2'-0" Epoxy coated - #5 = 3'-0"

GENERAL NOTES:
 This rail has been evaluated to be of equal strength to the T4 (A) railing, which has been crash tested to meet NCHRP Report 350 TL-3 criteria. This rail can be used for speeds of 50 mph and greater when a TL-3 rated guard fence transition is used. When a TL-2 rated guard fence transition is used, this rail can only be used for speeds of 45 mph and less.
 Do not use this railing on bridges with expansion joints providing more than 5' movement.
 Rail anchorage details shown on this standard may require modification for select structure types. See appropriate details elsewhere in plans for these modifications.
 Submit erection drawings showing panel lengths, rail post spacing, and anchor bolt setting, to the Engineer for approval.
 Average weight of railing with no overlay: 263 plf total
 234 plf (Conc)
 29 plf (Steel).

Cover dimensions are clear dimensions, unless noted otherwise.
 Reinforcing bar dimensions shown are out-to-out of bar.

TRAFFIC RAIL			
TYPE T401			
FILE: r151006-18.dgn	DATE: T401	BY: T401	NO. JTR
PROJECT: March 2013	COUNTY: HEB	SECTION: HEB	NO. 14
DISP:	COUNTY:	SHEET NO.	

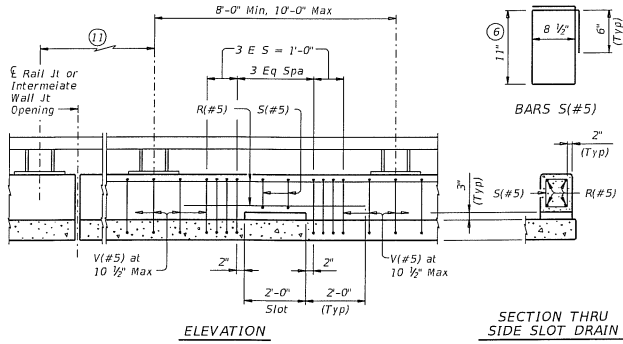

OPTIONAL SIDE SLOT DRAIN DETAILS

Note: Center Side Slot Drains between rail posts within the limits shown. Side Slot Drains may be used where shown elsewhere on the plans or as directed by the Engineer. Do not place drains over railroad tracks, lower roadways, or sidewalks. When this rail is used as a separator between a roadway surface and a sidewalk surface, side drain slots will not be permitted.

1/2" Dia heavy hex head anchor bolt (ASTM F3125 Gr A325 or A449) or threaded rod (ASTM A193 Gr B7 or F1554 Gr 105) with one hardened steel washer (ASTM F436) and one 2 1/2" O.D. steel washer placed under heavy hex nut (ASTM A563). One additional heavy hex nut must be furnished and tack welded for each threaded rod.

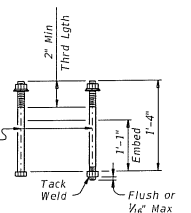

CAST-IN-PLACE ANCHOR BOLT OPTIONS